

Freezing-Thawing Laboratory Testing of Frost Susceptible Soils

Amin Zeinali. Corresponding / primary author
Lulea University of Technology, Sweden, amin.zeinali@ltu.se

Deniz Dagli. Co-Author
Lulea University of Technology, Sweden

Tommy Edeskär. Co-Author
Lulea University of Technology, Sweden

ABSTRACT

Frost heave and thaw weakening are two common concerns in designing and constructing roads throughout cold region areas. Cold regions can be defined in terms of air temperature and frost penetration by frozen ground engineering. Researchers have been studying frost action in soil for the past 85 years in order to design ways to reduce the costly damage to roads. Conducting the test on frost-susceptible soil must be done in order to retrieve data for frost heave and thaw weakening modeling in the soil body during a certain freezing-thawing cycle. This paper reviews and discusses the apparatuses used for this purposes. The studied apparatuses are cylindrical and provide heat through one dimension. The studied apparatuses mostly differ in the diameter and length of their cylindrical cell; likewise, temperature gradients differ from one apparatus to another. In this study the LTU's apparatus which was primarily designed to investigate the research related questions concerning freezing and thawing phenomena is presented in detail. The theory of segregation potential is applied for evaluation of the frost heave test and the thaw consolidation theory is applied for the thaw test. The main goal of the project is to conduct a series of experimental tests on various types of soil while exposing them to frost action in the apparatus to propose a classification system for the different types of soil in question with respect to their susceptibility to the frost action phenomena.

Keywords: Frost heave, Thaw weakening, Laboratory freezing test, Cold regions.

1 INTRODUCTION

Freeze-thaw action occurs in the cold regions of the world. As long as soil is frost-susceptible and temperature is cold enough to freeze the soil moisture, the freeze-thaw action is likely to happen. Large parts of northern Europe, Alaska, Canada, southern part of south America and large parts of the United States are known as cold regions. Cold region areas can be either permafrost area (where the ground is partly frozen even in summer) or seasonal frost. In these regions soil structures are subject to freezing during winter time and also thaw weakening during spring. Consequently, frost heave in

pavement structures and thaw weakening occur during freeze-thaw action. Seasonal temperature decrements result in changed mechanical properties of subgrade soil. Expansion (heave) of the saturated freezing soil may be about 9% of the freezing pore water volume and if there is access to an external source of water, this water will also be drawn into the frost front thereby forming ice lenses. Ice lenses expand upwards and consequently secondary frost heaves form inside the soil. The resulting frozen soil in the subgrade increase the stiffness of the unbound layers in the winter as well as frozen soil due to ice bonding of the soil particles in the base and sub-base layers. During winter the stiffness of the pavement

structure increases which is not an issue from a structural point of view. Frost heave is not problematic as long as it does not result in an uneven pavement, yet this is highly unlikely. On the other hand during spring, thaw weakening occurs and the reduction of stiffness in the pavement structure will cause road settlement. Thawed ice trapped between the deeper frozen layers and the surface saturates the thawed part of the pavement structure and as results consolidation occurs. The excessive water can weaken the pavement materials to the point where load restrictions must be applied to prevent pavement failure. These load restrictions are a severe burden on the trucking industry and the economic vitality of the affected regions. (Miller, 1980)

The damage to pavement due to freeze-thaw action in the road costs millions of euros annually. Therefore, it is highly important for road authorities to understand the phenomena in order to reduce the costs of maintenance and/or rehabilitations, as well as costs sustained by customers. Research on freeze-thaw action has been in focus for over 85 years with numerous studies being conducted in the 1980's. Researchers have simulated freeze-thaw action in their bench-scale studies in order to understand the fundamental mechanisms associated with freeze-thaw action and susceptibility of the commonly used materials in the pavement structure. The purpose of this paper is to review some of the equipment employed in freeze-thaw tests, and also some important findings from different laboratory tests are discussed. Finally Lulea University of Technology's setup is presented and explained in detail.

2 FROST ACTION IN SOIL

Frost heave is vertical displacement of the soil surface due to freezing. It involves heave formation as a result of the freezing of the in-situ moisture of soil, followed by formation of secondary frost heave due to segregation. Freezing of the soil moisture is termed in-situ freezing. Due to the negative pore pressure at the frost front, free water (in case there is

access to free water) is drawn into the frost front and forms ice lenses. Depending on how quickly the frost penetration develops, in-situ freezing will be affected accordingly. In general, the main portion of heave is primarily formed as a result of formation of ice lenses, and partly due to in-situ freezing. In the event of a quick soil freezing process, the role of in-situ freezing becomes more pronounced, however, the segregation process (formation of ice lenses) still accounts for a larger portion of the heave formed. When winter commences and the soil surface temperature starts to decrease frost front develops downwards. Ice lenses will form whenever extracted energy from soil in the frost front is equal to the energy provided by the underlying soil in the form of latent heat or the heat of crystallization released as water freezes. The growth of ice lenses depends on accessibility to free water and stability in thermal gradients.

Thawing in frozen soil can be explained in a way similar to that explained for freezing. When the air temperature is positive, thaw front starts to develop downwards as long as soil is frozen (seasonal frost conditions). However, the thawing process is hindered according to the thermal condition (permafrost condition). Thaw settlement involves a phase change, from ice to water; it also involves the outwards flow of excess water. Drainability plays an important role when it comes to excess pore pressure in thawed soil. Depending on how fine-grained the soil is, consolidation in thawed soil has a higher impact on thaw settlement. (Andersland O.B. Ladanyi B. 2012). Typical thaw settlement test result is shown in figure 1. Where e is void ratio, e_f is donates the frozen void ratio and e_{th} the thawed void ratio. When pressure increased by an amount $\Delta\sigma$, consolidation will occur until new equilibrium void ratio e is attained at point d.

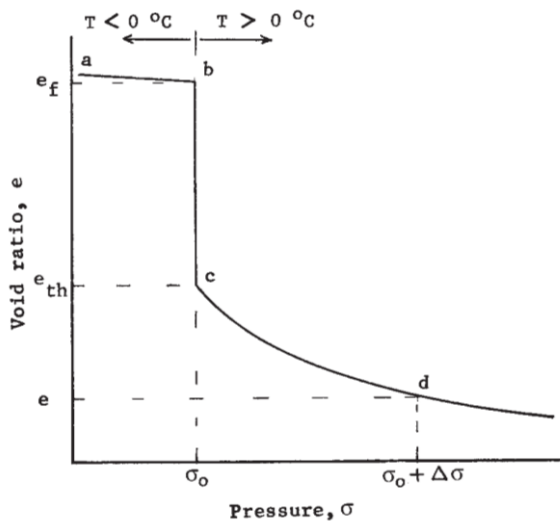

Figure 1 Typical void ratio pressure curve for frozen soil subjected to thawing. (Andersland O.B. Ladanyi B. 2012)

3 PARAMETERS TO BE CONSIDERED

Temperature profile, frost heave, thaw settlement and pore pressure are common measurements during the freeze-thaw tests. Depending on the purpose of the research, one or several parameters can be measured during the freeze-thaw tests. Frost front penetration and thaw front penetration are determined using the temperature profile. The frost heave measurement during tests can be recorded applying the LVDT (linear variable differential transformer) transducer. The frost heave test will be used to verify the existing theories regarding frost heave determination. It is important to keep track of water intake in the freezing soil. Keeping track of pore pressure during the tests gives a better understanding of thaw settlement and thaw weakening. In order to understand the importance of these measurements, frost front calculations, thaw consolidation theories, and segregation potential theory will be discussed briefly.

3.1 The modified Berggren equation

This equation yields a value for frost penetration which is the product of a correction factor and the frost front penetration value calculated from the Stefan

equation. The Stefan equation assumes a linear temperature distribution. Equation 1 is the Stefan equation for calculating frost front penetration (Andersland O.B. Ladanyi B. 2012).

$$X = \alpha \sqrt{t} \tag{1}$$

Where X is frost depth in meters, t is time in seconds, and α (m/\sqrt{s}) is a constant and α is computed using equation 2.

$$\alpha = \sqrt{\frac{2k_s T_0}{L}} \tag{2}$$

Where k_s ($W/m, c$) is thermal conductivity, T_0 ($^{\circ}C$) is annual temperature, and L (J/m^3) is latent heat. The Stefan equation does not take account of the volumetric heat; therefore the values calculated for frost front penetration are overestimated in the literature when the Stefan equation is applied. The modified Berggren equation gives the ultimate frost depth reached by the frost line within the soil.

Figure 2 Correction coefficients in the modified

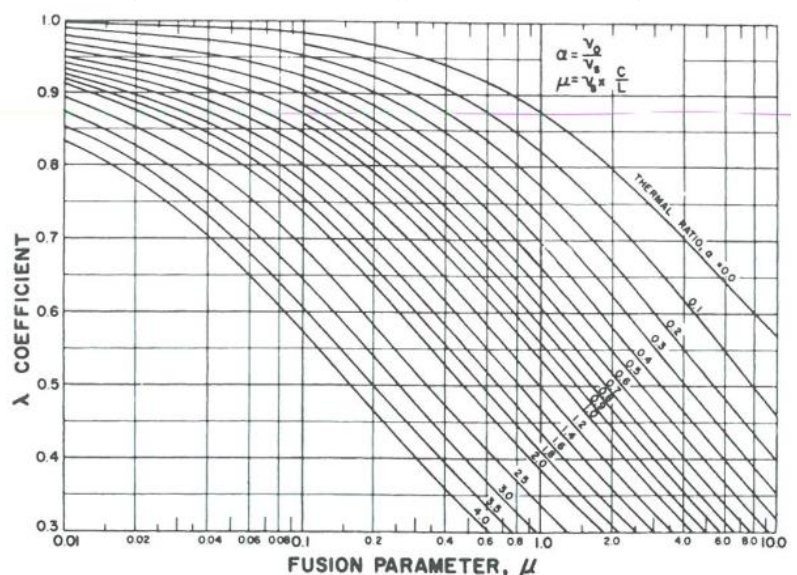

Berggren equation. (Andersland O.B. Ladanyi B. 2012)

The dimensionless correction coefficient, λ , is multiplied by the frost penetration depth computed from the Stefan equation.

Both α and μ in figure 2 are dimensionless. α is thermal ratio and μ is fusion parameter.

$$\alpha = \frac{v_0}{v_s} = \frac{v_0 t}{I_{sf}} \quad (3)$$

$$\mu = \frac{c_v v_s}{L} = \frac{c_v I_{sf}}{L t} \quad (4)$$

Where c_v ($\text{kJ}/\text{m}^3 \cdot ^\circ\text{C}$) is the soil volumetric heat capacity, L (kJ/m^3) is the volumetric latent heat, v_0 is initial surface temperature, v_s is surface temperature at the onset of the freezing period, I_{sf} is the surface freezing index and t is the duration of the freezing index.

3.2 Thaw consolidation theory

Based on the thaw consolidation theory assumptions, frozen soil is uniform, isotropic, homogeneous, and temperature is constant throughout the entire frozen fraction. Warm temperature from the top surface makes the frozen fraction start to thaw while the heat flow is assumed to be one dimensional (Andersland O.B. Ladanyi B. 2012).

Figure 3 shows the one dimensional thaw consolidation theory.

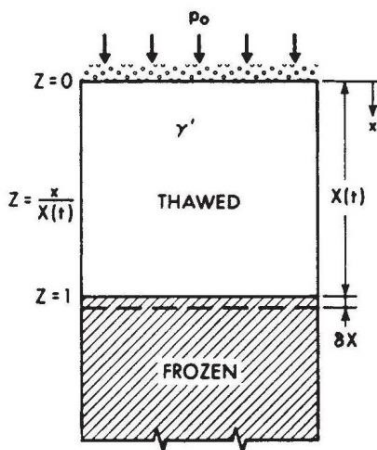

Figure 3 One-dimensional thaw consolidations. (Andersland O.B. Ladanyi B. 2012)

Thaw depth (X) is computed from equation 1. Where α is the thermal constant which depends on the initial temperature of the soil, the step temperature applied to the surface of the soil, and the thermal properties of both frozen and thawed soil. The Terzaghi

consolidation theory for saturated soil is assumed to be valid for the thawed region.

3.3 Segregation potential theory

The Segregation potential theory (SP) was introduced by Konrad and Morgensten in 1980. It is defined as the ratio of water migration rate to the overall migration rate in the frozen fringe, in order to characterize a freezing soil. (Kujala, 1991).

Due to negative pore pressure at the frozen fringe, water will be drawn in and new ice lenses start to form. As long as the ice lens develops frost front does not move. Equation 5 is the segregation potential equation by Konrad and Morgensen (Konrad, 1980).

$$v(t) = SP(t) \text{grad } T_f(t) \quad (5)$$

Where $v(t)$ is the flow of water to the growing ice lens at the time of the formation of the final ice lens, $\text{grad } T_f(t)$ is the overall thermal gradient in the frozen fringe and $SP(t)$ is a constant. This theory can be used to calculate the amount of heave as a result of freezing in the soil. Overburden load has a descending exponential impact on the segregation potential (Konrad, 1980).

4 FROST HEAVE AND THAW WEAKENING APPARATUSES

Frost and thawing problems were highlighted in 1930 by Stephen Taber. Researchers in cold regions tried to conduct laboratory scale tests in order to simulate frost action in soil and understand it. The main goal of freezing-thawing tests within these years was soil classification with respect to frost and thaw susceptibility. Several classifications have been proposed based on frost susceptibility of soil and still there is hope to improve it. In this paper we review some of the lab setups within the past 85 years. The reviewed frost heave and thaw weakening apparatuses have similarities and the principles are the same. They are all cylindrical in shape and the heat flow is one dimensional. The differences are mainly the accessibility to free water, diameter, height, temperature gradients,

overburden pressure, cooling system, and degree of saturations. According to the literature, none of the test apparatuses is 100 percent desirable. Most of them are not able to accommodate coarse-grained materials, for instance the base materials, because of the small diameter of the cylinder. (Chamberlain, E.J. 1981)

In other words, similarities of freezing-thawing apparatuses are:

- Specimen is cylindrical,
- Water is provided from the bottom (if applicable)
- Surface of the specimen is exposed to the freezing or thawing temperature
- Heat source is at the bottom
- Specimen is insulated

Direction of freezing is from top to bottom in most of the cases. In this study, the reviewed freezing thawing apparatuses are classified into two groups with respect to the cooling system:

1. Circulating air (top cap) and heated water (bottom cap):

In this case the entire freezing-thawing apparatus should be placed in a cold chamber. During the freezing test, circulation of the freezing air removes heat from the specimen surface while during the thawing test, the specimen surface extracts heat from the circulating air.

2. Circulating glycol/alcohol water:

In this case a cooling unit circulates a cold coolant such as a mixture of glycol/alcohol-water, through the top cap placed on the surface of the specimen. In order to provide heat at the other end, the coolant should be circulated through the bottom cap as well. Two separated cooling unites are needed for each specimen. Although the specimen is insulated, the entire freezing-thawing apparatus should be maintained at a constant temperature (cold chamber) in order to prevent heat extraction from the ambient.

Three different conditions are found in the literature regarding the water supplied to the specimen for frost heave and thaw weakening

tests: Konrad (1980) used fully saturated soil before the test and tried to keep it saturated during the test by keeping the water level as high as the surface of the specimen. Some researchers used saturated specimens, but they kept the water level at the base of the specimen. In some cases unsaturated specimens were used. (Kujala 1991).

In most of the cases overburden pressure can be applied although there are few exceptions. (Kujala 1991).

Table 1 mentions some of the selected apparatuses used. In most cases the principal goal is to classify soil frost susceptibility.

Table 1 Diameter, height and temperature gradient of some apparatuses.

Research	Year	D (cm)	H (cm)	Cold end (°C)	Temperature gradient (°C/cm)
Taber	1930	8.4	16	-17	1.22
Alekseeva	1957	6	10	-7	0.80
USACE	1970	14	12.7	-15	1.50
Aguirre-Puente	1970	7.5	25	-5.7	0.27
Vlad	1980	10	20	-25	1.45
Brandl	1970	30	50	-24	0.56
Brandl	1980	12.5	15	-15	1.27
Henry	2001	10	15	-1.4	0.21
Kolisoja	2003	15	15	-3	0.27

5 ASTM: D5918

The American Society for Testing and Materials (ASTM) proposed a standard for frost heave and thaw weakening tests. It is standard test methods for frost heave and thaw weakening susceptibility of soils. It should be used for soils where frost-susceptibility considerations are met, meaning that particle size should exceed the limit of 3% finer than 20 mm. This test is to estimate the relative degree of frost-susceptibility of soil used in pavement systems. ASTM proposes two freeze-thaw

cycles on compacted soil specimens, 146 mm in diameter and 150 mm in height. The soil specimen is frozen and thawed by applying specified constant temperatures in steps at the top and bottom of the specimen. Water can be supplied freely or the test can be run without access to free water. A surcharge of 3.5 kPa can be applied to the top. Test procedure can be completed within five days.

Table 2 shows frost susceptibility criteria based on ASTM. It is classified in six categories from negligible frost-susceptible soil to very high frost susceptible soil.

Table 2 Frost-susceptibility criteria (American Society for Testing and Materials 2013)

Classification	8-h Heave rate mm/day	Bearing ratio after thaw, %	Symbol
Negligible	<1	>20	NFS
Very low	1 to 2	20 to 15	VL
Low	2 to 4	15 to 10	L
Medium	4 to 8	10 to 5	M
High	8 to 16	5 to 2	H
Very high	>16	<2	VH

The bearing ratio is determined after the second thawing cycle. The ASTM method can be used to determine the frost-susceptibility of soil and thaw weakening susceptibility.

This method is not applicable to permafrost conditions and is only recommended for seasonal frost conditions. The amount of frost heave or thaw weakening cannot be predicted by the ASTM method. A schematic of the ASTM apparatus is illustrated in figure 4.

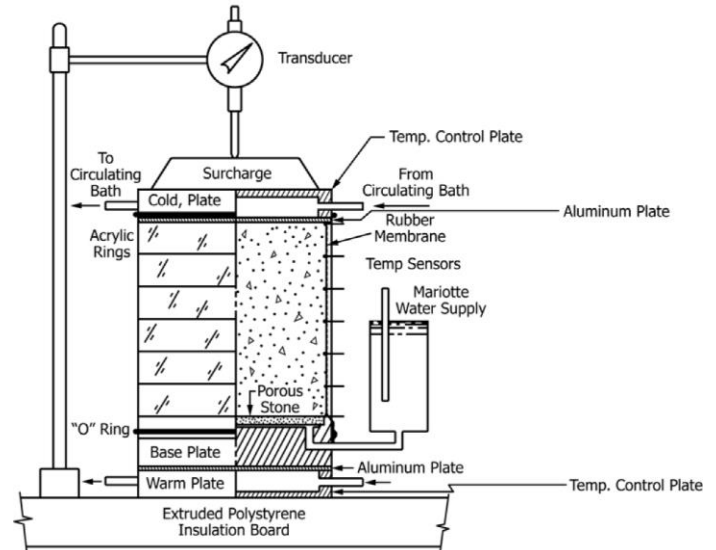

Figure 4 Specimen assembly for freezing tests by ASTM D 5918. (American Society for Testing and Materials 2013)

6 LTU APPARATUS

Lulea University of Technology (LTU) began specializing in frost action on soil during the 70s and 80s. Interest in this topic has experienced a resurgence in Sweden and LTU has seized the opportunity to continue research on frost action. The setup was further developed recently by Oulu university researchers in Finland. The new apparatus at LTU is based on the improved design and great support is received from Finnish colleagues. To begin, we reviewed the most recent progress and improvements. The principles of LTU apparatus are quite similar to the reviewed apparatuses. Heat flow is one dimensional, water is supplied from the bottom, side insulated, glycol-water coolant is supplied to both cold and warm ends, it is also possible to apply overburden load, the apparatus is cylindrical with a diameter of 10cm, and the specimen is 10cm in height. There is also a possibility to use taller specimens for the same apparatus if there is a need to do so.

A schematic of the LTU apparatus including the data logger system is shown in figure 5.

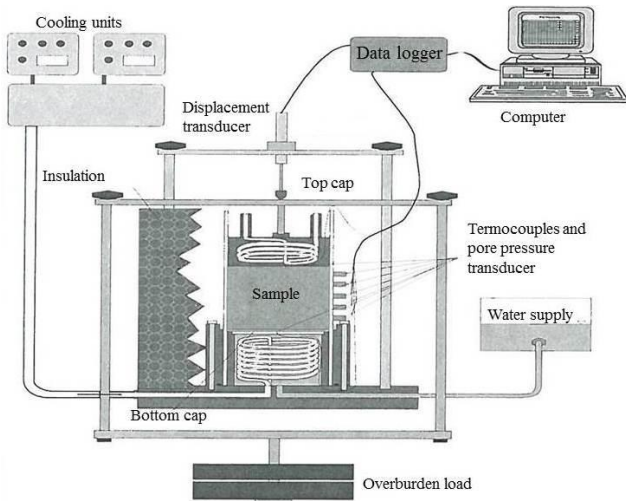

Figure 5 Sketch of LTU freezing-thawing apparatus(Kujala 1991)

Transparent cell is used and after the freezing-thawing test, there is a possibility to check out the soil profile and the formed ice lenses due to the freezing tests allows image analysis of the freezing-thawing test. In this case insulation shouldn't be used; therefore, heat flow will be three dimensional. A comparison between the images gives frost/thaw penetration as well as frost heave/thaw settlement. Frost/thaw penetration and frost heave/thaw settlement can be computed by image analysis. There is a possibility to compare the calculated frost/thaw penetration and the measured frost heave/thaw settlement to image analysis results in order to verify the functionality of the apparatus. Figure 6 the specimen it is exposed to freezing tests after 4 days.



Figure 6 Specimen during freezing test after 4 days

Friction between the top cap and cell during frost heave was one of the main concerns at LTU. The manufactured apparatus reduces friction between the top cap and cell and between the cell and frozen soil by allowing the cell to move upwards as the soil freezes. Thus preventing the soil and top cap from moving against the cell.

Figure 7 shows different parts of the freezing-thawing apparatus. Freezing units, load cells, membrane, thermocouples, and the data logger are not shown in this figure.

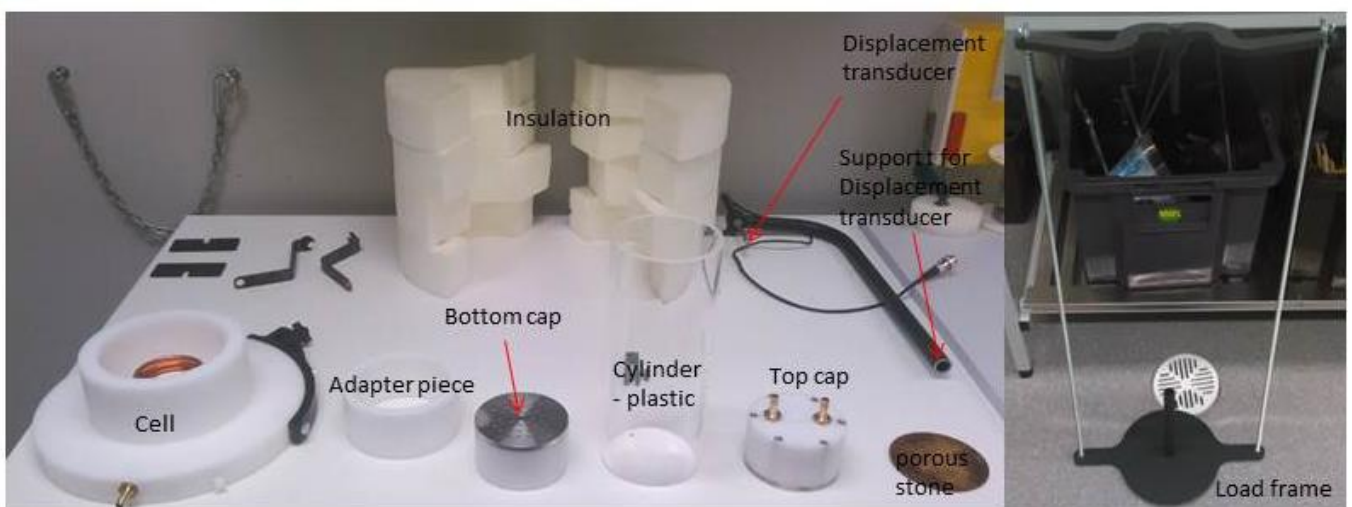

Figure 7 Freezing-thawing apparatus parts

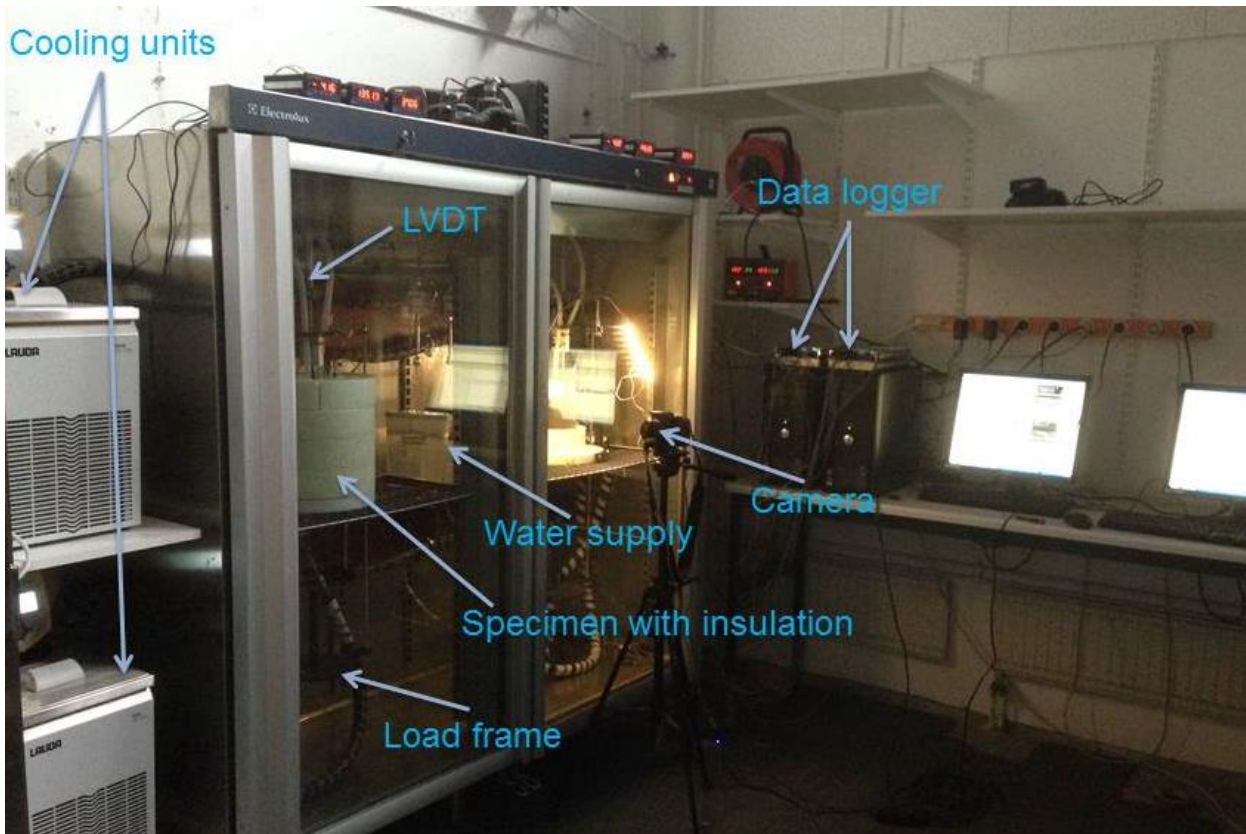

Figure 8 LTU frost lab

The specimen should be prepared and compacted to a desired degree of compaction. Compaction is done in five layers to prepare a uniform specimen in terms of density and fine particles. Prior to compaction a desired amount of water (10% water content) will be added to the soil. When conducting a freezing test on a saturated specimen, a membrane must be wrapped around the cell after placing the cell on the bottom cap. The membrane is important to keep the moisture in the specimen and to secondly fill the gap between the cell and the edge of the bottom cap, while the water level is kept at the level of the specimen surface. There is a possibility to run the test on undisturbed samples. If so, the core sample should be prepared with a diameter of 10cm (equal to that of the apparatus cylinder), then gently transferred to the freezing-thawing cylinder. Five holes are created on the cell for thermocouples, and five holes for pore pressure transducers. Two holes have been created for drainage in order to keep the water level at the bottom of the specimen during the experiment.

Thermocouples should be attached gently and ASTM recommends that thermocouples be inserted 6.5 mm into the specimen. After assembling the unit and connecting it to the cooling units, thermocouples, LVDT, pore pressure transducers and load cell will be connected to the data logger. The freezing-thawing apparatus is shown in figure 8.

7 FREEZING-THAWING TEST DATA

Several pre-tests have been conducted at LTU and in this paper some topline results are presented. During the freezing test water intake has been recorded (which causes the ice lenses when the sample is saturated), frost heave and frost depth. Five thermocouples are used to measure temperature in the soil in 2 cm intervals. When the frost depth is located between two of the thermocouples interpolation method is applied to find the zero temperature location (frost front). Frost heave, water intake and frost penetration will be used for modeling and frost susceptibility classification.

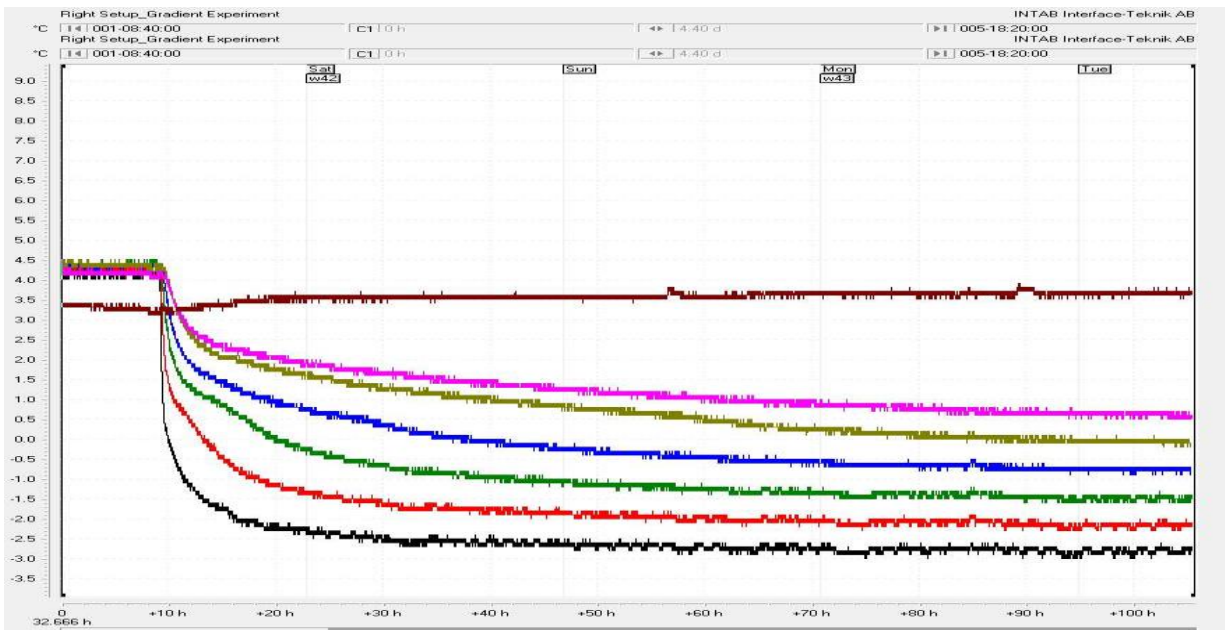

Figure 9 Thermocouples data for freezing test

Figure 9 shows the thermocouples data. Two thermocouples are attached to the cold and warm ends and the rest are inserted into the soil to represent soil profile temperature. Frost penetration depth and heave measured by LVDT from one of the pre-tests are illustrated in figure 10 and 11 respectively. Basically these are input data for further investigations.

These data has been discussed and analyzed in the other paper written by the same authors. Dagli et al. (2016) discussed the relationship between heave and net heat extraction rate based on these data.

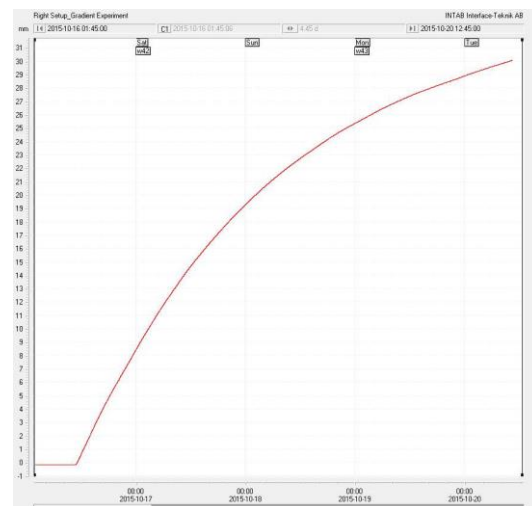

Figure 11 Frost heave (mm) LVDT readings

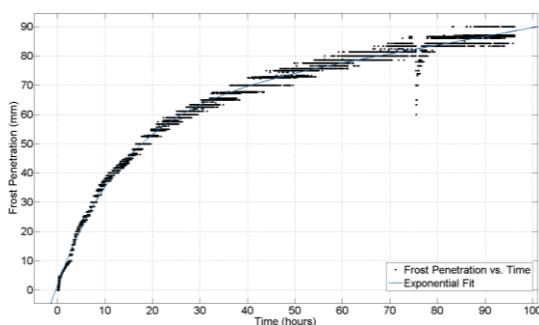

Figure 10 Frost penetration curve (mm)

8 CONCLUDING REMARKS

The LTU apparatus is one of the most latest bench-scale apparatus designed for freezing and thawing tests. In terms of basic design such as dimension, heat flow, insulation etc. there are similarities to the pervious setups and thanks to more advanced data loggers and transducers, LTU apparatuses is more friendly user. Moreover, LTU apparatus is the most complete setup in terms of both frost and thaw action in the soil. In addition to modeling frost action there is a possibility

to improve soil susceptibility classification. For classification, plenty of freezing-thawing tests on various types of soil should be conducted as well as basic soil mechanic laboratory tests. Soil will be classified based on their properties and the degree of frost susceptibility will be defined.

9 ACKNOWLEDGMENT

The authors would like to acknowledge the financial support of research project by Swedish Transport Administration (Trafikverket).

10 REFERENCES

- Andersland OB, Ladanyi B. (2012). FROZEN GROUND ENGINEERING. American Society Of Civil Engineering; 2012.
- ASTM Standard D5918-13, (2013). "Frost Heave and Thaw Weakening Susceptibility of Soils," ASTM International, West Conshohocken, PA 19428-2959. United States
- Beskow, G. (1935) soil freezing and frost heaving with special applications to roads and railroads, Swedish Geol. Survey year book 26(3), No.375.
- Boyd, D.W. (1976). Normal freezing and thawing degree-days. Canadian Geotechnical Journal, vol.13. pp:176-80
- Chamberlain EJ. Frost susceptibility of soil. Hanover, New Hampshire: Cold Regions Science and Engineering; 1981.
- Dagli, D., Zeinali, A., Laue, J and Edeskär, T. (2016). Theoretical Analysis of the Relationship between Heave and Net Heat Extraction Rates Based on Freezing Experiments Data. The 17th Nordic Geotechnical Conference, Reykjavik, Iceland.
- Darrow MM, Huang SL, Shur Y, Akagawa S. Improvements in frost heave laboratory testing of fine-grained soils. J Cold Regions Eng. 2008;22(3):65-78.
- Drumm ECM, R. LTPP Data Analysis: Daily Seasonal Variations in In-situ Material Properties. Knoxville, Tennessee: National Cooperative Highway Research Program; 2003. Report No.: NCHRP Web Document 60.
- Kettle MRJ, Williams RIT. (1976). Frost heave testing. Matériaux et Constructions. 1976;9(4):310.
- Konrad, J.M. (1980). Frost Heave Mechanics. Ph.D. thesis, University of Alberta, Alberta.
- Konrad, J.M, Morgenstern, N.R. (1981). The segregation potential of a freezing soil. Canadian Geotechnical Journal, vol.18. pp:482-91
- Kujala K. (1990). Factors Affecting Frost Susceptibility And Heaving Pressure In Soils. 1st ed. Oulu University, editor. Oulu: Oulu University; 1991.
- Ladanyi B. (1981). Mechanical behaviour of frozen soils. In proc.Int. symp. on Mechanical Behaviour of Structured Media, Carleton Univ. Ottawa. New York:Elsevier, vol. B, pp 205-45.
- Miller RD. (1980). Freezing phenomena in soil. Application of soil physics. 1980:254-99.
- Miller RD. Freezing phenomena in soil. Application of soil physics. 1980:254-99
- Nixon, J. (1987). Ground freezing and frost heave review. The Northern Engineering, Vol. 19, No. 3&4, pp.8-18.
- Niu, F.J. Cheng, G.D and Lai, Y.M. (1998). Laboratory study on a Duct-Ventilated Roadbed of Qinghai-Tibet International permafrost conference. Zurich, Switzerland. pp:815-820.
- Taber, S. Freezing and Thawing of soils as Factors in the destruction of the Road Pavements. Public Roads, Vol. 11, March 1930-February 1931, pp. 113-132.
- Saarenketo,T., Scullion, T. and Kolisoja, P. (1998). Moisture Suceptibility and Electrical Properties of Base Course Aggregates. In fifth International Conference on the Bearing Capacity of Roads and Airfields, Trondheim, Norway, 1998, pp. 1401-1410.
- Zarling, J.P., Barley, W.A., and Ecsh, D. (1988). Thaw Stabilization of Roadway Embankments. 5th International Permafrost Conference, Trondheim, Norway, vol.2. pp:1352-1357.